

E

Axial fans for toilet and bathroom



E versalite range combining basic units with its accessories. Water-proof.

Applications: For open air ventilation of small enclosures or through reduced length conduits.

CHARACTERISTICS

MODEL	∅ mm	m ³ /h	230 V / 50 Hz W	dB (A)
E 100	98	90	12	43
E 120	117	180	18	48
E 150	148	300	25	52

DIMENSIONS (mm)

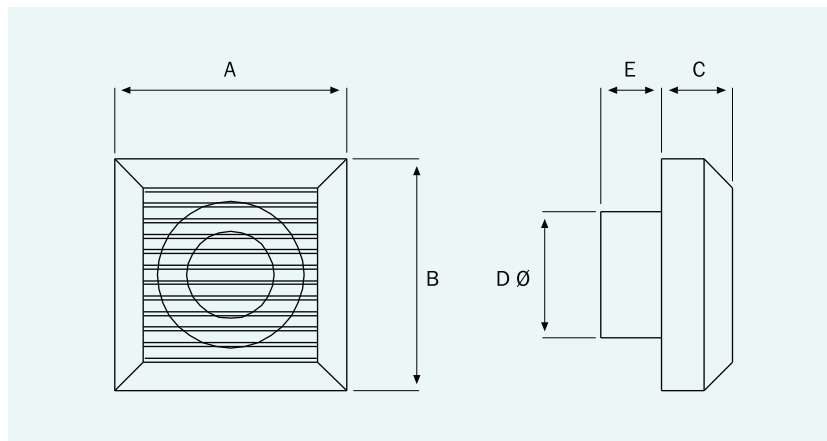

MODEL	A / B	C	D ∅	E
E 100	155	25	98	56+14
E 120	173	30	117	56+18
E 150	210	30	148	56+18

Surface	Model to install
Up to 4 m²	A 100
Up to 6 m²	A 120
Up to 11 m²	A 150